



Heckmann Building Products Inc.

1501 N. 31st Avenue

Melrose Park, IL 60160-2911

800-621-4140 or 708-865-2403 Fax: 708-865-2640

www.heckmannbuildingprods.com

SUBMITTAL SHEET: #425 WEDGE INSERTS (SHELF ANGLE INSERTS) #427 ASKEW HEAD BOLTS

Standard Sizes:

Inserts: 5/8", 3/4", and 3/4" Long. Available in Plain Malleable Iron or Hotdip Galvanized After Fabrication.

Bolts: 5/8" x 1-1/2", 2", 2-1/2", and 3".
3/4" x 1-1/2", 2", 2-1/2", 3", and 3-1/2".

Available in Plain, Electro Galvanized After Fabrication, or Hotdip Galvanized After Fabrication. Bolts come with a nut and washer. Bolts extend 1/4" less than above lengths when installed in inserts.

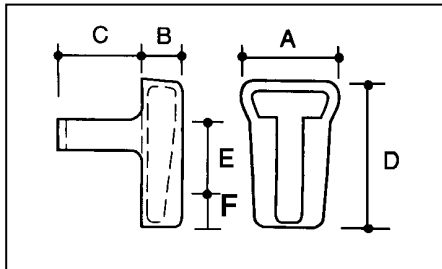

Dimensions (in inches)

Bolt Dia.	Cat. No.	A	B	C	D	E	F
5/8"	425-5	2-1/4	1-1/32	1-15/16	3-5/8	1-5/8	1"
3/4"	425-6	2-5/16	1-3/16	2-1/2	3-7/8	1-3/4	1"
3/4 Long	425-6L	2-1/4	1-1/4	2-3/8	5-1/2	3	1"

(E is the Vertical Adjustment for Askew Head Bolts)

(F is the dimension from the bottom of the insert to the center of the bolt)

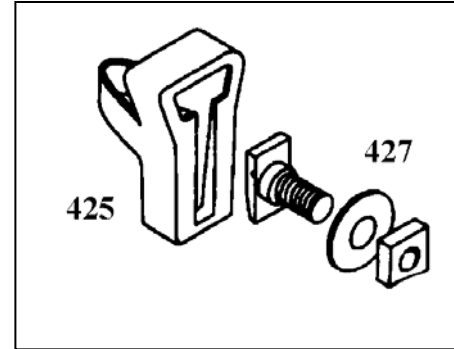
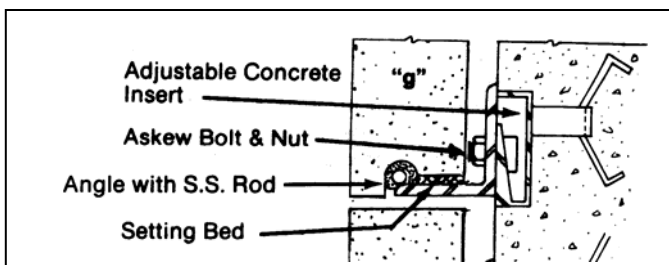

Malleable Iron Specifications: ASTM A47-B4
Ferritic Malleable Iron Castings
Class/Grade 32510 Min Tensile Strength -
PSI 50,000
Min. Yield Strength - psi 32,500 Elongation
in tension 10%
Microstructure is Temper carbon and ferrite
For additional information on Specifications of
Shelf Angle Inserts
refer to the following:
NCMA TEK 93 - National Concrete Masonry
Institute - Curtain and Panel walls of Concrete
Masonry. 1977
BIA TECH NOTE 28B - Brick Institute of
America - Brick Veneer Panel and Curtain
Walls. February 1980
ANSI B18.2.1 1965 revised 1970 - Askew Head
Bolts - American National Standards Institute.

Approvals:

Comments: