



Heckmann Building Products Inc.

1501 N. 31st Avenue

Melrose Park, IL 60160-2911

800-621-4140 or 708-865-2403 Fax: 708-865-2640

www.heckmannbuildingprods.com

SUBMITTAL SHEET: #342-B; L-ANCHOR WITH 2 SLOTS

MADE TO ORDER:

Thickness: 3/16", 1/8", 11 gage, 12 gage, 14 gage, 16 gage.

Width: 1" wide minimum recommended.

Length: Specify overall length of leg from inside of bend to the end of the anchor.

Bend Length: 1" i.d. minimum recommended.

Specify diameter of hole and location.

Specify slot size and location.

Available in Plain Steel, Mill Galvanized Steel, Electro Galvanized After Fabrication, Hotdip Galvanized After Fabrication, Rolled Strip Zinc Alloy, or Stainless Steel.

Stainless Steel:

Sheet metal anchors and ties: ASTM A 167 AISI Type 304.

Plate and bent bar anchors: ASTM A 666 AISI Type 304.

Wire ties and anchors: ASTM A 580 AISI Type 304.

Hotdip Galvanized:

ASTM A 153 Class B-2: (1.50 oz/ ft²)(0.46kg/m²)

Mill Galvanized:

Sheet metal anchors and ties: ASTM A 653 G60

Wire: ASTM A 641 (0.1 oz/ ft².)

Plain Steel:

Sheet Metal anchors and ties: ASTM A 569, ASTM A 366.

Plates, bars, and shapes: ASTM A 123, ASTM A 36.

Wire: ASTM A 82, ASTM A 82-95a.

Firewall Anchors:

Rolled Strip Zinc Alloy 710.

Firewall Anchors:

Rolled Strip Zinc Alloy 710.

(Firewall alloy 1/8" and 16 gage only)

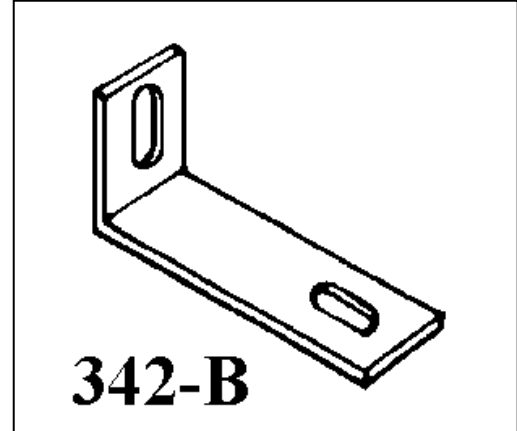

Approvals:

Comments: