



# Heckmann Building Products Inc.

1501 N. 31<sup>st</sup> Avenue

Melrose Park, IL 60160-2911

800-621-4140 or 708-865-2403 Fax: 708-865-2640

[www.heckmannbuildingprods.com](http://www.heckmannbuildingprods.com)

## SUBMITTAL SHEET: #340-A CORRUGATED L-ANCHOR WITH HOLE

Used to Anchor Brick Veneer to existing backup systems.

MADE TO ORDER:

Thickness: 3/16", 1/8", 11 gage, 12 gage, 14 gage, 16 gage.

Width: 1" wide minimum recommended. ( For hole sizes over 1/2" we recommend a minimum of 1/4" of steel on each side of the hole: i.e. for a 3/4" hole minimum width should be 1-1/4")

Length: Specify overall length of corrugated leg from inside of bend to the end of the anchor.

Bend Length: 1" i.d. minimum recommended.

Specify diameter and location of hole in the bend. (we recommend hole size to be 1/16" larger than the screw size. i.e. for a 1/4" screw we punch a 5/16" diameter hole.)

Available in Plain Steel, Mill Galvanized Steel, Electro Galvanized After Fabrication, Hotdip Galvanized After Fabrication, or Stainless Steel.

### **Stainless Steel:**

Sheet metal anchors and ties: ASTM A 167 AISI Type 304.

Plate and bent bar anchors: ASTM A 666 AISI Type 304.

Wire ties and anchors: ASTM A 580 AISI Type 304.

### **Hotdip Galvanized:**

ASTM A 153 Class B-2: (1.50 oz/ ft<sup>2</sup>)(0.46kg/m<sup>2</sup>)

### **Mill Galvanized:**

Sheet metal anchors and ties: ASTM A 653 G60

Wire: ASTM A 641 (0.1 oz/ ft<sup>2</sup>.)

### **Plain Steel:**

Sheet Metal anchors and ties: ASTM A 569, ASTM A 366.

Plates, bars, and shapes: ASTM A 123, ASTM A 36.

Wire: ASTM A 82, ASTM A 82-95a.

### **Firewall Anchors:**

Rolled Strip Zinc Alloy 710.

(Firewall alloy 1/8" and 16 gage only)

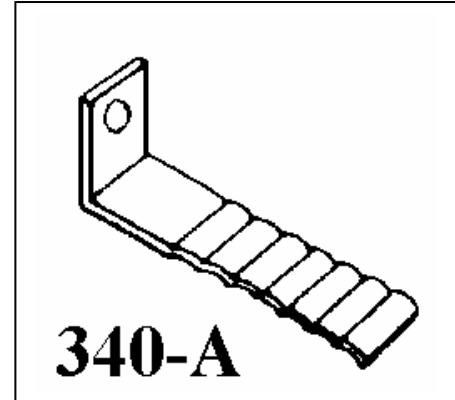

Approvals:

Comments: