



# Heckmann Building Products Inc.

1501 N. 31<sup>st</sup> Avenue  
Melrose Park, IL 60160-2911  
800-621-4140 or 708-865-2403 Fax: 708-865-2640  
www.heckmannbuildingprods.com

## SUBMITTAL SHEET: #147 TWISTED SPLIT-BEND STONE ANCHOR

Made to order:

Thickness: 1/4"\* , 3/16", 1/8", 11 gage, 12 gage, 14 gage,  
& 16 gage.

Width: minimum width recommended is 1-1/4". Minimum  
width for 1/4" thick is 2" wide.

Length: minimum length 2-1/2" long i.d. (specify as i.d.  
dimension)

Bend: minimum 3/4" i.d.

Split Bend: minimum 3/4" i.d.

Available in Stainless Steel, Hotdip Galvanized After  
Fabrication, Electro Galvanized After Fabrication, Mill  
Galvanized, or Plain Steel.

Standard Twist is 2" Long.

\*1/4" thick Stainless Steel Twisted anchors are not  
available. 3/16" is thickest in Stainless. Available Twist  
thickness & widths

thickness	max SS width	max mild width
1/4"	n/a	1"
3/16"	1-1/4"	1-1/4"
1/8"	1-1/2"	1-1/2"

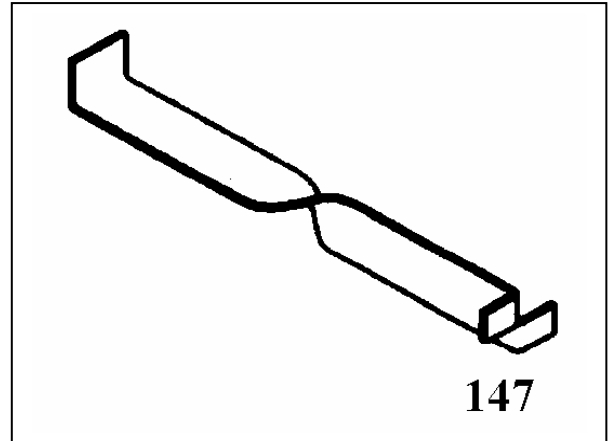

### Stainless Steel:

Sheet metal anchors and ties: ASTM A 167 AISI Type 304.

Plate and bent bar anchors: ASTM A 666 AISI Type 304.

Wire ties and anchors: ASTM A 580 AISI Type 304.

### Hotdip Galvanized:

ASTM A 153 Class B-2: (1.50 oz/ ft<sup>2</sup>)(0.46kg/m<sup>2</sup>)

### Mill Galvanized:

Sheet metal anchors and ties: ASTM A 653 G60

Wire: ASTM A 641 (0.1 oz/ ft<sup>2</sup>.)

### Plain Steel:

Sheet Metal anchors and ties: ASTM A 569, ASTM A 366.

Plates, bars, and shapes: ASTM A 123, ASTM A 36.

Wire: ASTM A 82, ASTM A 82-95a.

### Firewall Anchors:

Rolled Strip Zinc Alloy 710.

(Firewall alloy 1/8" and 16 gage only)

Approvals:

Comments: