



Heckmann Building Products Inc.

1501 N. 31st Avenue

Melrose Park, IL 60160-2911

800-621-4140 or 708-865-2403 Fax: 708-865-2640

www.heckmannbuildingprods.com

SUBMITTAL SHEET: #133-P CHANNEL-SLOT BRIDGE PLATE

Used as a washer for attaching Heckmann Channel Slots to existing walls with Expansion Anchors or other Fasteners. Bridge Plate conforms to the shape of the Channel Slots.

See #133 Long Channel Slots

Standard Size: 12 Gage x 1-1/2" across x 1" high with 1/2" lips. Available with either a 7/16" or 5/16" hole in Plain Steel, Mill Galvanized, Electro Galvanized After Fabrication, Hotdip Galvanized After Fabrication, or Stainless Steel.

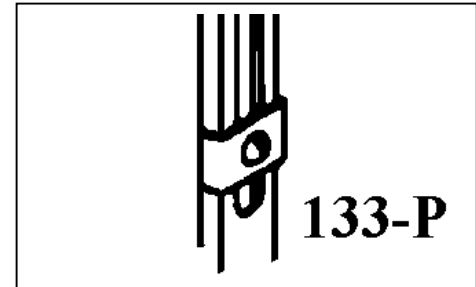
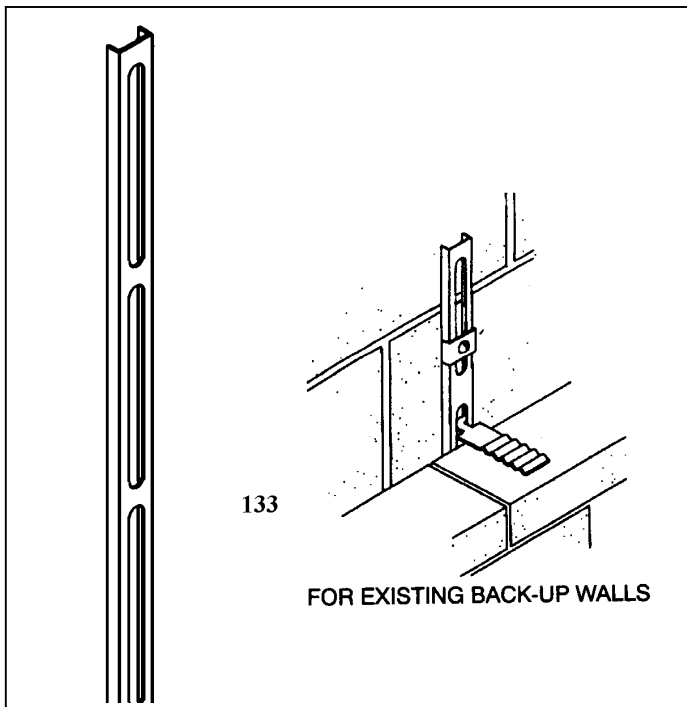

Stainless Steel:

Sheet metal anchors and ties: ASTM A 167 AISI Type 304.

Plate and bent bar anchors: ASTM A 666 AISI Type 304.

Wire ties and anchors: ASTM A 580 AISI Type 304.

Hotdip Galvanized:

ASTM A 153 Class B-2: (1.50 oz/ ft²)(0.46kg/m²)

Mill Galvanized:

Sheet metal anchors and ties: ASTM A 653 G60

Wire: ASTM A 641 (0.1 oz/ ft².)

Plain Steel:

Sheet Metal anchors and ties: ASTM A 569, ASTM A 366.

Plates, bars, and shapes: ASTM A 123, ASTM A 36.

Wire: ASTM A 82, ASTM A 82-95a.

Approvals:

Comments: