



Heckmann Building Products Inc.

1501 N. 31st Avenue
Melrose Park, IL 60160-2911
800-621-4140 or 708-865-2403 Fax: 708-865-2640
www.heckmannbuildingprods.com

SUBMITTAL SHEET: #117-A LARGE DOVETAIL SPLIT-BEND STONE ANCHOR

(Used only with #100-A Large Dovetail Anchor Slot)

Made to Order:

Used to attach stone to a concrete backup wall that has #100-A Large Dovetail Anchor Slot. Stone should have kerfs cut in the top and bottom.

Dovetail Section is 1-7/8" across x 1-9/16" deep.

Thickness: 1/8" maximum

Width: 2" minimum

Length: Specify length as measured from Face of Concrete to the outside of the anchor split-bend.

Split-Bend: 3/4" i.d. minimum.

Available in Stainless steel, Hotdip Galvanized After Fabrication, Electro Galvanized After Fabrication, or Mill Galvanized.

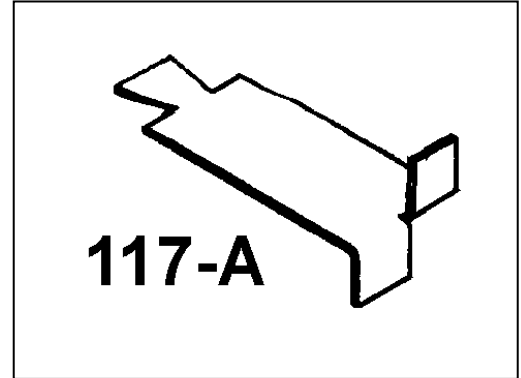

Stainless Steel:

Sheet metal anchors and ties: ASTM A 167 AISI Type 304.

Plate and bent bar anchors: ASTM A 666 AISI Type 304.

Wire ties and anchors: ASTM A 580 AISI Type 304.

Hotdip Galvanized:

ASTM A 153 Class B-2: (1.50 oz/ ft²)(0.46kg/m²)

Mill Galvanized:

Sheet metal anchors and ties: ASTM A 653 G60

Wire: ASTM A 641 (0.1 oz/ ft².)

Plain Steel:

Sheet Metal anchors and ties: ASTM A 569, ASTM A 366.

Plates, bars, and shapes: ASTM A 123, ASTM A 36.

Wire: ASTM A 82, ASTM A 82-95a.

Firewall Anchors:

Rolled Strip Zinc Alloy 710.

(Firewall alloy 1/8" and 16 gage only)

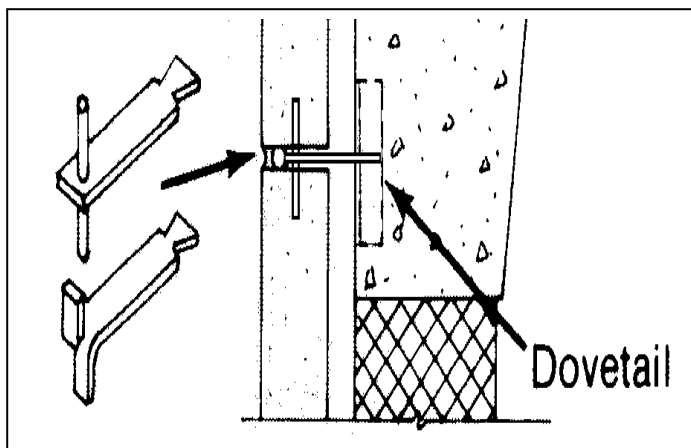

Approvals:

Comments: