

Failures

Preventing Safety Failures

Updating reinforced CMU wall installation

In the early 20th century, steel rebar was used with hollow-core concrete masonry units (CMUs) to build structurally stable walls. However, there has been little progress since then with regard to how these components can be placed.

Whether capped or uncapped, rebar is usually positioned in a raised, stationary, and exposed manner. In addition to obstructing the mason's field of view, there is the potential for numerous problems with this 'time-tested' building method. Workers can not only be endangered by the spear-like exposed steel, but they can also experience extreme lower back and shoulder stress due to material positioning over the stationary rebar. Along with possible exposure to the repetitive motion injuries, this can mean decreased productivity and increased material/labor cost (including workers' compensation).

This traditional CMU rebar reinforcement technique can diminish overall wall strength, limiting its structural capability. Current rebar locators have limited function, and can be insufficient in achieving balanced design. Vertical length of stationary rebar do not coincide with horizontal modular CMU wall construction.

Newer—and safer—methods are becoming available to provide better quality control. With one technology, the mason uses an adjustable holder that 'telescopes' about 1.5 m (5 ft) of rebar for precise, centered placement in a hollow-block core. (Adjustment is possible for each level or course installed.) This allows selective vertical and horizontal rebar positioning, while eliminating the physical overhead lifting of heavy block and potentially lowering incidents of back stress injuries. At the

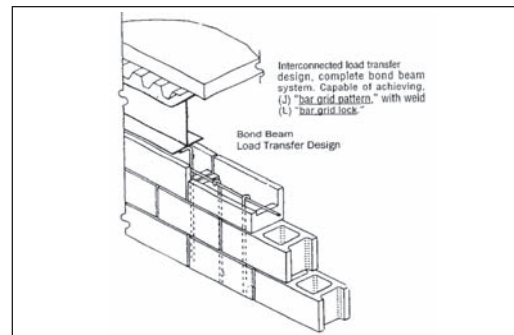
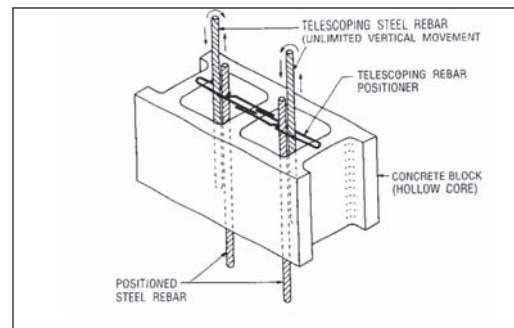

New installation methods can improve safety.

same time, accurate and secure placement can help minimize the prospects of rebar waste.

These telescoping systems also help ensure natural and mechanical bonds with grout. Additionally, adjustable rebar holders can eliminate the need to grout block wall cores in sections, helping with seismic design by offering a monolithic pour without waste. They also allow shift load transfer when the hooked rebar is vertically adjusted into place over horizontal bond beam rebar and both are then hooked down together. (L-shaped rebar could be welded to the structural steel above.) Additionally, this method enables vertical rebar to cross horizontal bond beam rebar at the top of masonry walls, forming a bar grid pattern. ♡



Bradley S. Dressler developed the Steel-wich method, which uses an adjustable rebar holder for positioning inside masonry walls. He is a 14-year journeyman bricklayer with International #3 in Buffalo, New York. More information can be found at heckmannbuildingprods.com. Dressler can be contacted at (716) 683-7526. Tim Dressler is a consultant to Steel-Wich. He has more than 23 years of experience as an architectural designer. Working with professional engineers, his area of expertise is custom residential and commercial buildings. He can be reached at adcdesign4u@yahoo.com.